



Product introduction

The louver box-type temperature, humidity, pressure, and illumination CO2 sensor is a fully digital detection, high-precision sensor. It is integrated with high-precision digital temperature, humidity, air pressure, CO2 and high-sensitivity silicon blue photovoltaic detectors as illumination sensors. Quickly detect atmospheric temperature, atmospheric humidity, illuminance, CO2 and air pressure values, the built-in signal processing unit can output corresponding signals according to user needs, the high-strength structure design can accurately detect in harsh climate environments, and can be widely used in meteorology, ocean, environment, airports, ports, laboratories, industry and agriculture and transportation and other fields.

Technical Parameters

Type	Measuring range	Accuracy	Resolution
Temp	-50~100℃	±0.5℃	0.1℃
Humidity	0~100%RH	±5%RH	0.1%RH
pressure	500 ~ 1100hPa	±0.3hPa	0.1hPa
illumination	0-200000Lux	±7%	1Lux
CO2	0~2000ppm	±(40ppm+2%F·S)	1ppm

Power supply:

- DC 12V
- DC 24V
- Other

Output:

- RS485
- Other

Load resistance: Voltage type: $RL \geq 1K$

Current type: $RL \leq 300 \Omega$

Working temperature: -50℃~80℃

Relative humidity: 0~100%

Connection method

- (1) If equipped with the collector produced by our company, directly connect the sensor to the corresponding interface on the collector using the sensor cable.
- (2) If the transmitter is purchased separately, the matching line sequence of the transmitter is as follows:

Line color	Output signals		
			communication
Red			+
Black (Green)			-
Yellow			A+/TX
Blue			B-/RX

Structural dimensions

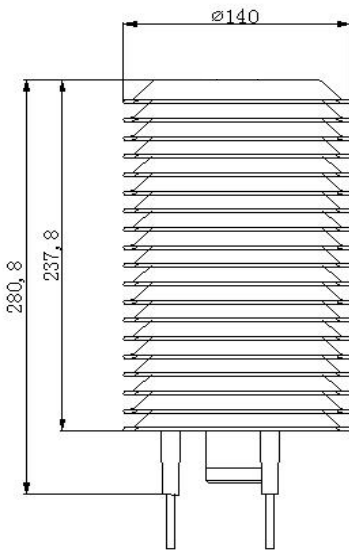

MODBUS-RTU Communication protocol

I. Serial port format

Data bits 8 bits

Stop bit 1 or 2 bits

Check Digit None

Baud rate 9600 The interval between two communications is at least 1000ms

II. Communication format

【1】 Write the device address

Send: 00 10 Address CRC (5 bytes)

Returns: 00 10 CRC (4 bytes)

Instructions: 1. The address bit of the read/write address command must be 00.

2. Address is 1 byte, the range is 0-255.

For example: send 00 10 01 BD C0

return 00 10 00 7C

【2】 Read the device address

Send: 00 20 CRC (4 bytes)

Returns: 00 20 Address CRC (5 bytes)

Description: Address is 1 byte, the range is 0-255

For example: send 00 20 00 68

Return 00 20 01 A9 C0

【3】 Read real-time data

Send: Address 03 00 00 00 05 XX XX

Description: As shown in the figure below:

Code	Functional Definition	Remark
Address	Station number	

	(address)	
03	Function Code	
00 00	Start address	
00 05	Read points	
XX XX	CRC Check code, front low back high	

Return: Address 03 0A QW QW SD SD QY QY CO CO ZD ZD XX XX

Description:

Code	Functional Definition	Remark
Address	Station number (address)	
03	Function Code	
0A	Read unit bytes	
QW QW	Temperature data (front high and back low)	hex
SD SD	Humidity data (front high and back low)	hex
QY QY	Air pressure data (front high and back low)	hex
CO2 CO2	CO2 data (front high and back low) hex	hex
ZD ZD	Illumination data (front high and back low)	hex
XX XX	CRC Check code	

Steps to calculate CRC code:

1. The preset 16-bit register is hexadecimal FFFF (that is, all 1s). Call this register the CRC register;
2. XOR the first 8-bit data with the lower bits of the 16-bit CRC register, and place the result in the CRC register;
3. Shift the contents of the register one bit to the right (toward the lower bit), fill the highest bit with 0, and check the lowest bit;
4. If the lowest bit is 0: repeat step 3 (shift again)
If the lowest bit is 1: XOR the CRC register with the polynomial A001 (1010 0000 0000 0001);
5. Repeat steps 3 and 4 until the right shift is performed 8 times, so that the entire 8-bit data is

processed;

6. Repeat steps 2 to 5 to process the next 8-bit data;

7. The final CRC register is the CRC code;

8. When the CRC result is put into the information frame, the high and low bits are exchanged, and the low bits are first.

Temperature resolution 0.1 °C , humidity 0.1%RH, illuminance resolution 10Lux, carbon dioxide resolution: 1ppm

After hexadecimal is converted to decimal data, it needs to be multiplied by the corresponding coefficient, the temperature and humidity coefficient is: 0.1, the illuminance is 10, and the carbon dioxide is: 1

summer is about: 100,000 Lux (30,000 to 300,000 Lux);

Cloudy light intensity:

about 10,000 Lux;

Sunrise and sunset light intensity:

300-400 Lux;

Indoor fluorescent light intensity is about:

30 ~ 50 Lux;

Night:

0.3~0.03 Lux (under bright moonlight);

0.003~0.007 Lux (gloomy night);

installation method:

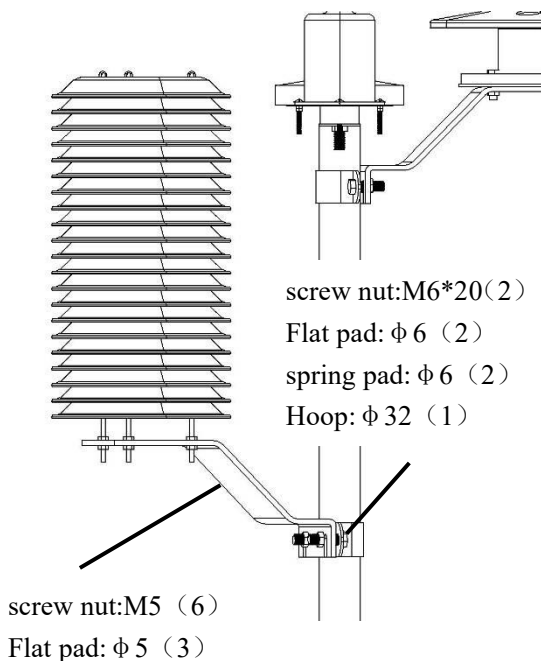

As shown in the picture above, it can be matched with the bracket and installed on the bracket.

Reference standard

1 unit of illuminance is about the brightness of 1 candle at a distance of 1 meter.

Illumination under strong light on a sunny day in

Notice

1. Please check whether the packaging is in good condition, and check whether the product model is consistent with the selection;
2. Do not connect with live power. After the wiring is completed and checked, the power can be turned on;
3. The length of the sensor line will affect the output signal of the product. Do not arbitrarily change the components or wires that have been soldered when the product leaves the factory. If you need to change it, please contact the manufacturer;
4. The sensor is a precision device, please do not disassemble it by yourself, or touch the surface of the sensor with sharp objects or corrosive liquid, so as not to damage the product;
5. Please keep the verification certificate and qualification certificate, and return it together with the product during maintenance.

Trouble clearing

1. When detecting the output, the indicator indicates that the value is 0 or not within the range. Check whether there is any obstruction by foreign objects. The collector may not be able to obtain information correctly due to wiring problems. Please check whether the wiring is correct and firm;
2. If it is not for the above reasons, please contact the manufacturer.